

Martin School Equipment



SeniorCare

Furniture
Collection

2010



Handcrafted and Assembled by Skilled Arkansas Craftsmen

SeniorCare Collection Design Specifications

Construction:

All cabinet parts (excluding sub-base and countertops/work surfaces) and any scribes/fillers shall be constructed of 3/4" or greater thickness Medium Density Fiberboard (MDF). Particle board is not used. Exposed surfaces shall be finished in selected laminate with interior parts in white melamine (sometimes called cabinet liner) unless otherwise specified. Exposed edges will be finished in selected edge treatment style and color or pattern. Quality plywood and solid-wood construction is also available.

Fixed cabinet parts shall be joined with 25mm (1") steel eccentric locks with all joints glued. Dividers and fixed shelves shall be dadoed into adjoining panels and glued in place or joined with eccentric locks where necessary.

Sub-base beneath base and tall cabinets shall be of pine 2x4 frame construction topped with plywood or O.S.B., nailed and glued together. Standard 3" depth toe-kick unless otherwise specified.

Countertops are constructed of 1/2" thick laminated particle board core with specified high pressure laminate applied, backer sheet applied where required for a balance sheet. Back-splash height of 4" is standard. 1" thick solid poured epoxy tops also available (recommended in lab and chemical rooms). Any holes or sink openings in epoxy tops should be specified by customer.

Shelves 24" wide or less will be 3/4" MDF (unless otherwise specified). Shelves from 24"-36" wide will be a minimum 1" thick. Any cabinet wider than 36" will have a divider to split shelf width. We do not make shelves over 36" wide, the deflection is too great. Standard shelf supports are 5mm brass shelf pins with 32mm (1 1/4") spacing CNC drilled for precise alignment. KV-255 steel shelf standards with steel shelf clips adjustable in 1/2" increments are also available when specified.

Drawer fronts are 3/4" MDF with selected laminate on exposed and white cabinet liner on unexposed faces (or selected laminate where specified) with selected edge treatment. Drawers are constructed using the Blum Metabox drawer system with steel powder coated drawer sides combined with 3/4" MDF drawer bottoms and backs (white cabinet liner unless otherwise specified). Drawers are available with the full line of Blum accessories including hanging folder rods and dividers. The Metabox drawer system has a 100 pound static load rating, a dynamic capacity of 75 pounds and has been tested to 100,000 open-close cycles without failure. We also offer a traditional box-jointed drawer constructed from 1/2" Russian birch plywood finished in our Chem-Aqua lacquer. The bottoms are 1/4" birch

plywood dadoed in on all sides. Standard drawer glides are either Blum full-extension rails with a rating of 100 lbs or K-V glides with a 75 pound load rating. Other combinations available where specified.

Hardware:

4" dull/satin chrome wire pulls are standard on doors and drawers. A wide selection on flush and other style pulls also available when specified.

Mobile cabinets will utilize a heavy-duty low-profile caster at each corner, recessed and concealed where possible. Casters will be rated to support at least 160 lbs each. Stationary, but moveable cabinets will employ a locking mechanism on one pair of casters to prevent accidental movement.

Standard hinges are full overlay five-knuckle wraparound hinges (Siquar #H0075 or approved equal), sometimes referred to as 'institutional hinges.' Optional self-closing European-style concealed hinges (Blum 120 or approved equal) also available.

Cabinets not utilizing self-closing hinges will have a 12-pound pull magnetic latch per door, doors taller than 48" will utilize 2 magnetic latches each.

Cabinets specified with locks will have disk tumbler flush mounted locks either keyed alike or individually keyed (as specified). Locking cabinets without means to lock both doors will have the non-locking door secured by interior thumb-latch.

Installation:

Installation shall be performed by experienced professional installers with knowledge of all aspects of the installation procedure. Installation will be performed per manufacturer recommendations as approved by architect or planner.

Martin School Equipment or its installers shall not be responsible for any Flooring (including cabinet base molding), Electrical, Plumbing, HVAC or Framing of Walls.

In cases of extremely crooked and/or out-of-plumb walls MSE will not be responsible for poor fitting tops and cabinets abutting those walls.

Warranty:

All cabinetry products are guaranteed against defects in workmanship or materials for a period of 2 years after date of completed installation.

SeniorCare Collection Design Notes

We've designed our SeniorCare Collection to meet a need we didn't feel was being adequately met in the marketplace. As more and more of the "baby boomer" generation reaches retirement age the rate of computer-literacy in their demographic has risen substantially. The SeniorCare line is not only designed with computer use in mind (CPU space becomes storage/shelving space where a computer is not required) it also aims to keep those enjoying it healthier and more comfortable. The scratch-resistant surface of the smooth laminated panels sealed with sprayed-on antimicrobial edging alongside powder coated steel drawer hardware makes cleanup/sanitization easier. Cleaner surfaces help in inhibiting the growth and spread of dangerous pathogens, including the dreaded MRSA bacteria. The available hidden locking casters and full line of Wilsonart® colors/patterns combined help to create a more inviting, comfortable homelike feeling.

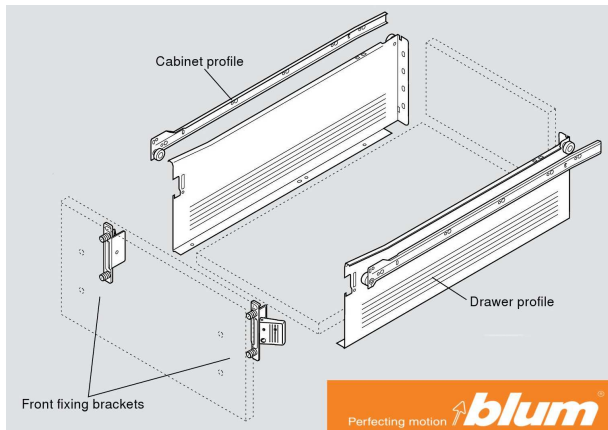

- Tough powder coated steel Blum Metabox drawer system glides smoothly and quietly for many years to come.

- Available antimicrobial and chemical resistant sprayed-on rubberized edge material (shown in black, available in colors) seals the edges of the panels. A sealed panel edge not only keeps out moisture and makes for easy cleaning, it also denies MRSA and other contagions a hiding spot. Extra deep keyboard trays are installed at ADA height for convenient wheelchair access.

- Optional concealed heavy-duty locking casters, accessible from the rear of the cabinet make units stable when locked down. Unlocked, the unit will roll easily out of the way, making cleaning, floor care or furniture rearrangement fast and easy.





**1-door, 1-drawer
Computer Cabinet**

No.
SCC1

WxHxD
32X34X23



**2-door, 1-drawer
Computer Cabinet**

No.
SCC2

WxHxD
32X34X23



Above: Sample room layout using pieces from our SeniorCare line.

Shown: Two-door, two-drawer wardrobe and one-door, one-drawer computer cabinet with custom headboard/footboard.



**3-drawer Dresser
with Keyboard Drawer**

No.
SCD3D

WxHxD
32X34X23



6-drawer Dresser

No.
SCD6D

WxHxD
48X34X23



2-door Wardrobe

No.
SCW2D4884
SCW2D3684
SCW2D4872
SCW2D3672

WxHxD
48x84x23
36x84x23
48x72x23
36x72x23



2-door, 1-drawer Wardrobe

No.
SCW2D1D4884
SCW2D1D3684
SCW2D1D4872
SCW2D1D3672

WxHxD
48x84x23
36x84x23
48x72x23
36x72x23



2-door, 2-drawer Wardrobe

No.	WxHxD
SCW2D2D4884	48x84x23
SCW2D2D3684	36x84x23
SCW2D2D4872	48x72x23
SCW2D2D3672	36x72x23



All-in-one Wardrobe

ADA-Compliant Wheel Chair Access

No.	WxHxD
SCWAIO	56x84x23

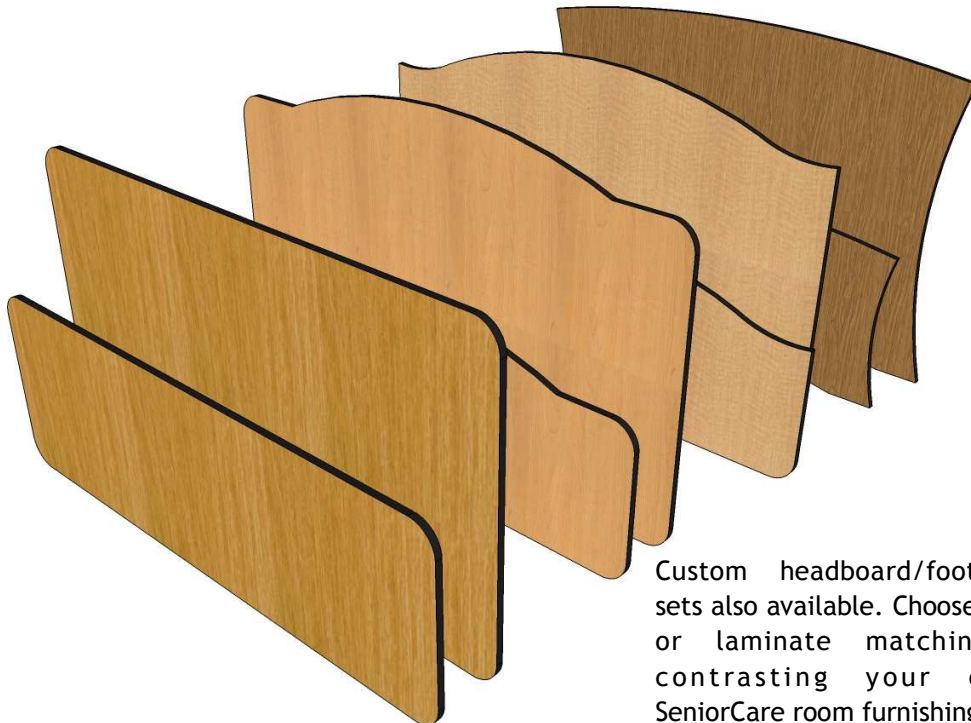

Custom headboard/footboard sets also available. Choose wood or laminate matching or contrasting your other SeniorCare room furnishings.

Martin School Equipment

www.martinschoolequipment.com

PO Box 263 - Suite A

Midway, AR 72651

Phone: 1-800-467-5808

Fax: 1-866-209-7256

E-mail:

info@martinschoolequipment.com

